

CLASS IV B-SERIES SIDE SHIFTER FOR MODELS BEGINNING 15B, 14B, 13B, 12B, 11B

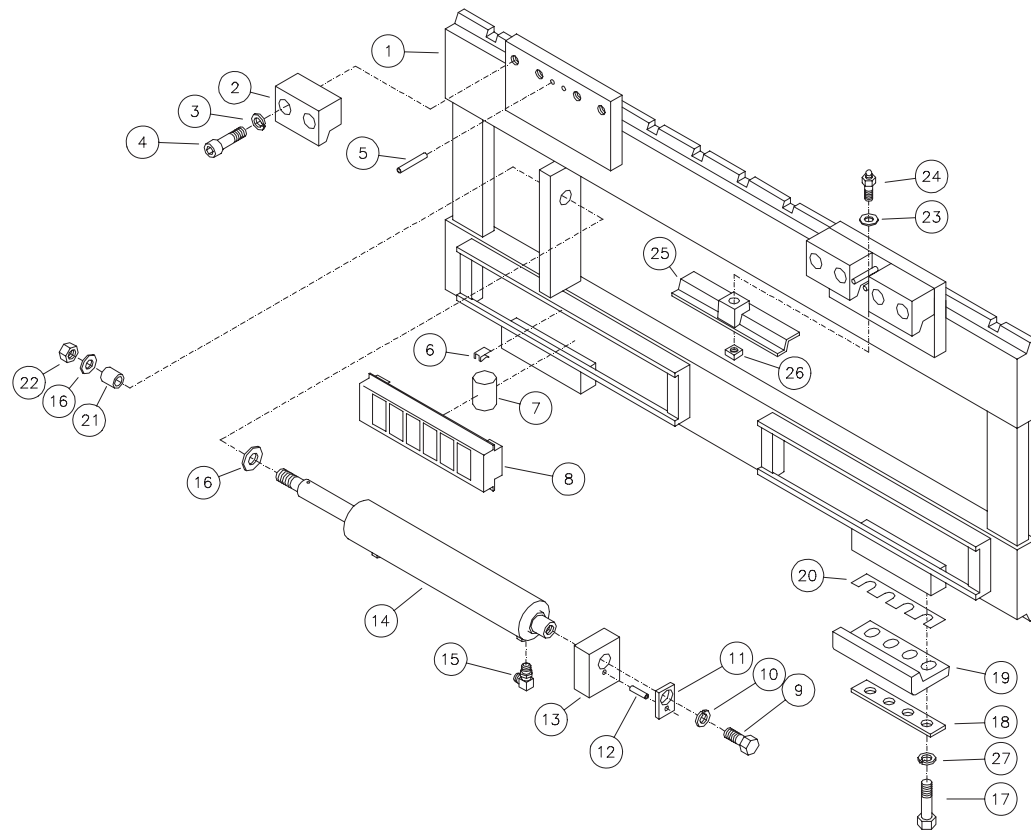

G146
10

ITEM	REQ'D	PART #	DESCRIPTION	ITEM	REQ'D	PART #	DESCRIPTION
1.	1	201-003*	ITA SIDE SHIFT FRAME	15.	2	120-051-002	FITTING
2.	4	006-003	HOOK	16.	2	404-009-002	FLAT WASHER
3.	8	402-017-004	LOCK WASHER	17.	8	405-067-003	CAP SCREW
4.	8	403-039-001	SOCKET HEAD SCREW CAP	18.	2	004-225	PLATE
5.	4	401-016-002	ROLL PIN	19.	2	005-401	ITA SLIDE/RETAINER
6.	2	417-001	SPRING CLIP	20.	6	041-002	SHIM
7.	12	047-004	ROLLERS HEAT TREATED	21.	1	046-009	BUSHING
8.	2	003-010	ROLLER CAGE	22.	1	406-023-002	NUT
9.	1	405-069-004	CAP SCREW	23.	2	404-002-001	FLAT WASHER
10.	1	402-016-002	LOCK WASHER	24.	2	408-002	GREASE FITTING
11.	1	004-007	PLATE	25.	2	005-402	ITA SLIDE/RETAINER
12.	1	401-016-001	ROLL PIN	26.	2	406-004-001	NUT
13.	1	101-153-003	CYLINDER ANCHOR	27.	8	402-016-003	LOCK WASHER
14.	1	C-340D	CYLINDER				

* Specify side shifter model or serial number when ordering.

CYLINDER C-340D

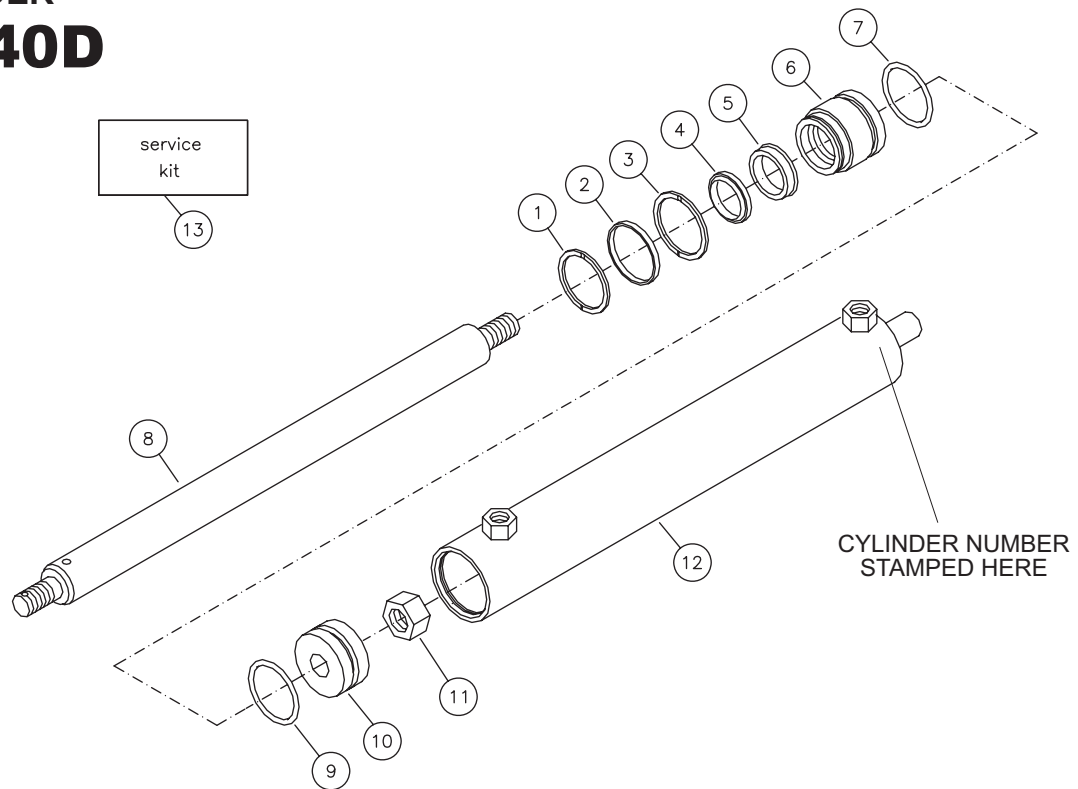
G881
7

ITEM	REQ'D	PART #	DESCRIPTION
1.	1	410-018-005	RETAINING RING
2.	1	046-041-006	BUSHING
3.	1	410-017-002	RETAINING RING
4.	1	124-007-002	ROD WIPER
5.	1	123-009-004	ROD/PISTON SEAL
6.	1	106-032-001	CYLINDER HEAD
7.	1	121-024-004	O-RING
8.	1	104-024-001	CYLINDER ROD
9.	1	121-023-002	O-RING
10.	1	105-003-001	CYLINDER PISTON
11.	1	406-023-002	NUT
12.	1	108-008-001	TUBE ASSEMBLY
13.	0	900-023-001	SERVICE KIT

SERVICE KIT NUMBER 900-023-001 INCLUDES

1	124-007-002	ROD WIPER
1	123-009-004	ROD/PISTON SEAL
1	121-024-004	O-RING
1	410-018-005	RETAINING RING
1	121-023-002	O-RING
1	410-017-002	RETAINING RING

- All seals are included in service kit.
Seals are not sold individually.

CLASS IV B-SERIES SIDE SHIFTER INSTALLATION INSTRUCTIONS FOR MODELS BEGINNING 15B, 14B, 13B, 12B, 11B

These Instructions cover B series ITA class IV models. Welding is required to install side shift cylinder anchor.

Please read the instructions completely before you begin. Keep hands and feet free from dangerous positions or pinch points while working. Wear eye protection and appropriate clothing. Use the correct tools. Work in a clean, well lighted area taking care not to contaminate the hydraulic system as serious damage could result. Protect cylinder rods and other critical surfaces from weld spatter or accidental damage.

Installing the Side Shift Cylinder Anchor

1. Carefully measure the truck carriage face as shown below and mark the cylinder anchor position. If the anchor does not contact the face of the upper carriage bar use an additional 1.0 inch thick extension plate 4.0 inches wide and as tall as necessary for your application. Position the extension plate between the carriage bars, flush with the face of the carriage as shown. Tack weld the extension plate to the carriage bar.
2. Position the cylinder anchor as illustrated and tack weld. Insure that the anchor is perpendicular to the face of the truck carriage. Carriages are made with various alloys. Contact the truck manufacturer for the recommended welding procedure. Finish weld as indicated.

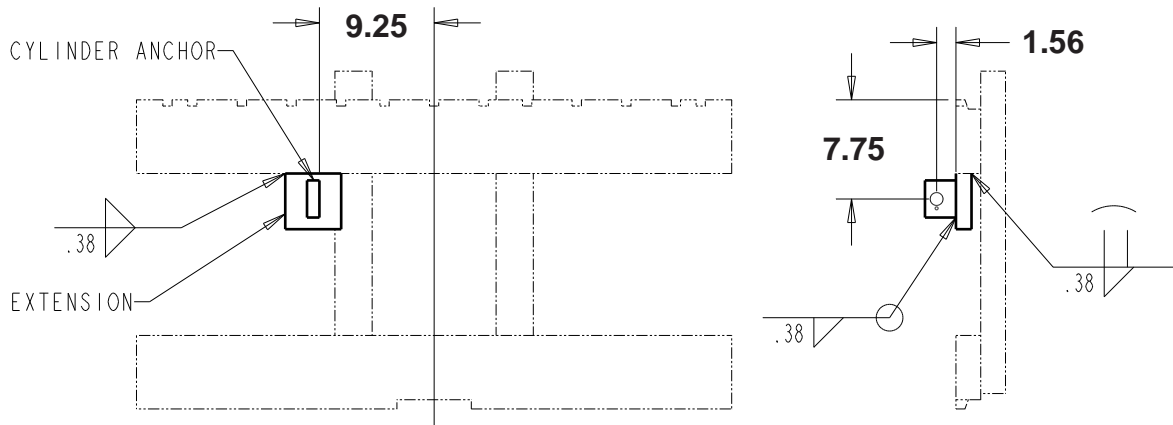

Mounting the Attachment

1. Remove the lower retainers.
2. Hang the side shifter on the truck carriage. Attach side shift cylinder to anchor.
3. Install the lower retainers as shown. Use the .060 inch thick shims to obtain the indicated clearance with bolts torqued to 75 ft. lbs. Save unused shims between the lower retainer and the cover plate.

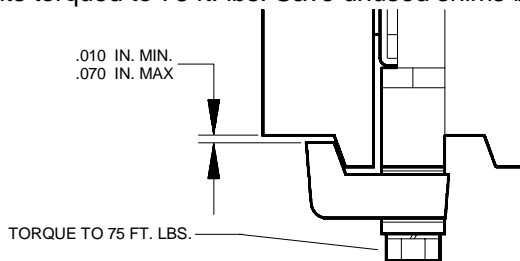

PRESSURE	RATE of FLOW
2,000 PSI RECOMMENDED	3.8 GPM RECOMMENDED
2,250 PSI MAXIMUM	2.8 GPM MINIMUM
	5.5 GPM MAXIMUM

4. Connect the cylinder to the hydraulic supply. ITA recommended practices suggest rearward or upward motion of the control lever to move the load right and forward or downward actuation to move the load left as viewed from the driver's seat. Insure that all hosing does not interfere with or wear against any part of the mast or sideshift carriage throughout the full range of operation.
5. Most installations require the use of a load backrest. Check local safety regulations prior to placing the lift truck in service.

If you have any questions or comments call (503)-556-1761 for technical assistance. Thank you for using Rightline products.

